

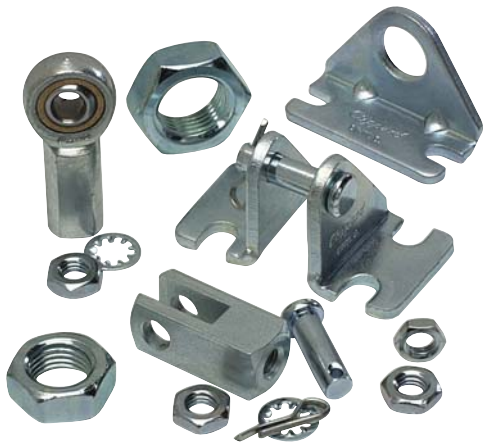

7/8" BORE ACCESSORIES



MOUNTING NUTS

Stud Nut

Part Number	Across Flats	Nut Thickness	Nut (Thread)
N10-18	15/16"	3/8"	5/8-18

Rod Nut

Part Number	Across Flats	Nut Thickness	Nut (Thread)
N04-28A	7/16"	5/32"	1/4-28
N04-28B	3/8"	1/8"	1/4-28

CB-1795

Clevis Bracket
Material: Steel, bright zinc plated

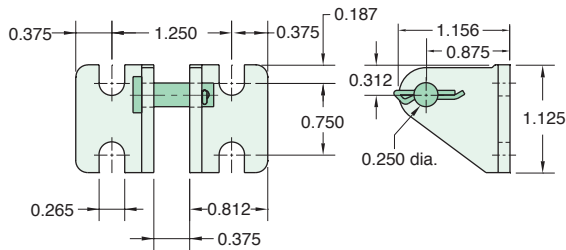

RC-1281

Rod Clevis
Material: Steel, electroless nickel plate

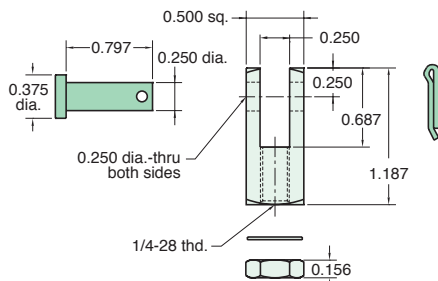

RE-1285

Rod End
Material: Steel, bright zinc plated body

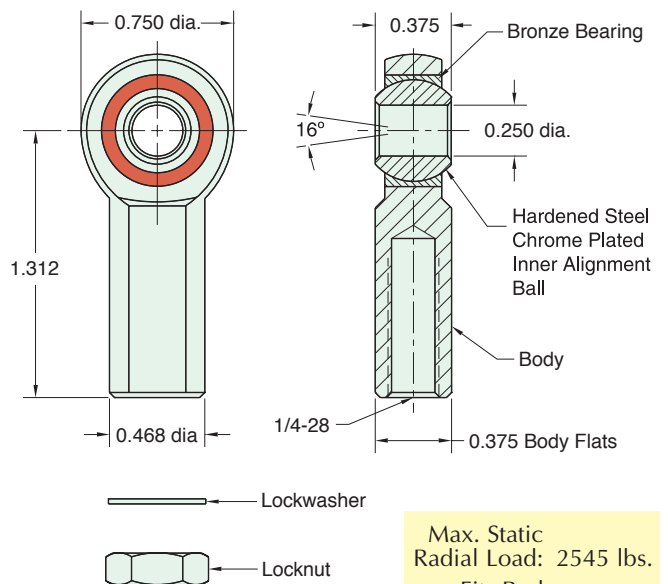

Max. Static Radial Load: 2545 lbs.
Fits Rod Thread Size: 1/4-28

FB-1791

Foot Bracket
Material: Steel, bright zinc plated

